

10.5 BW and TW axes

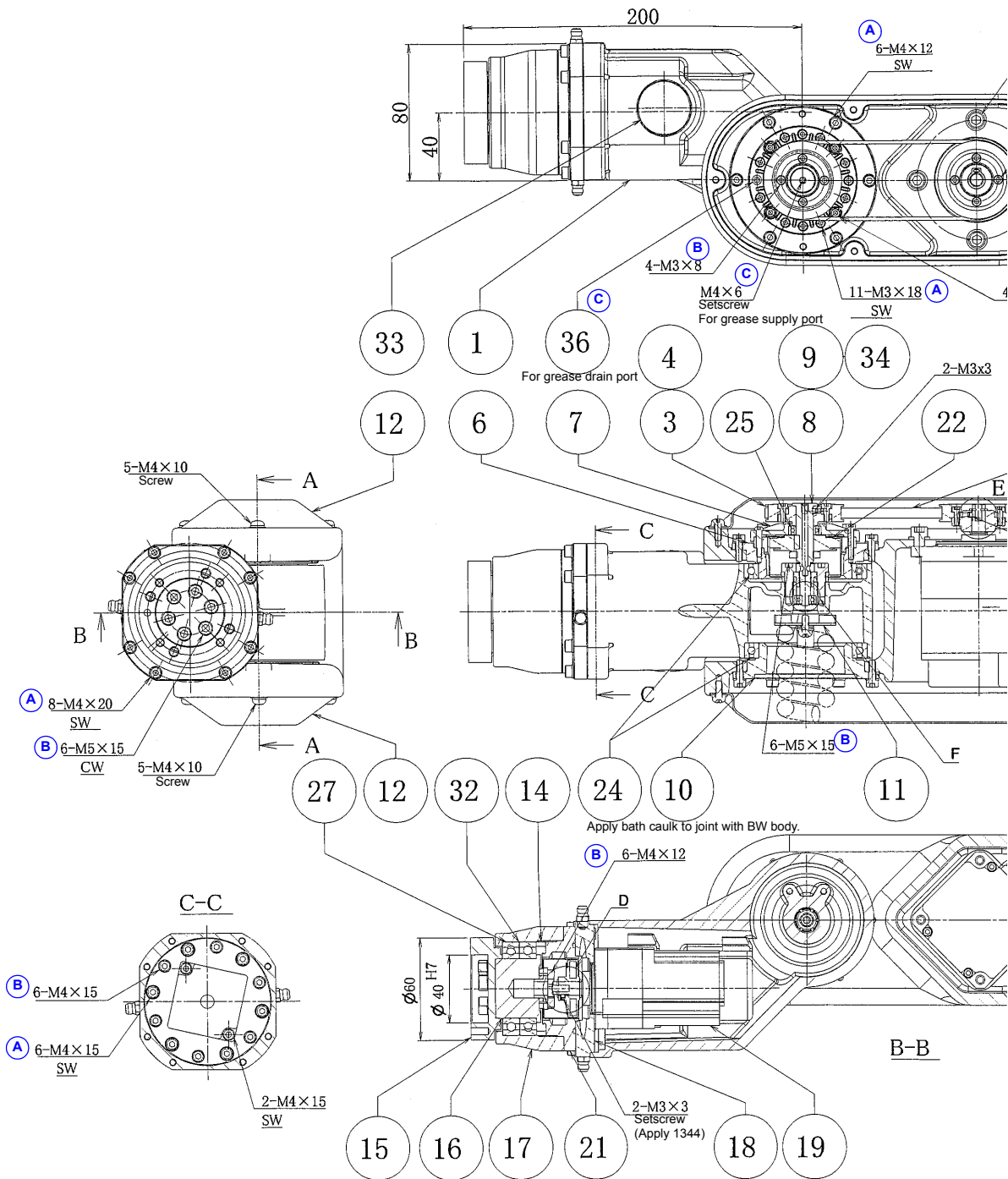

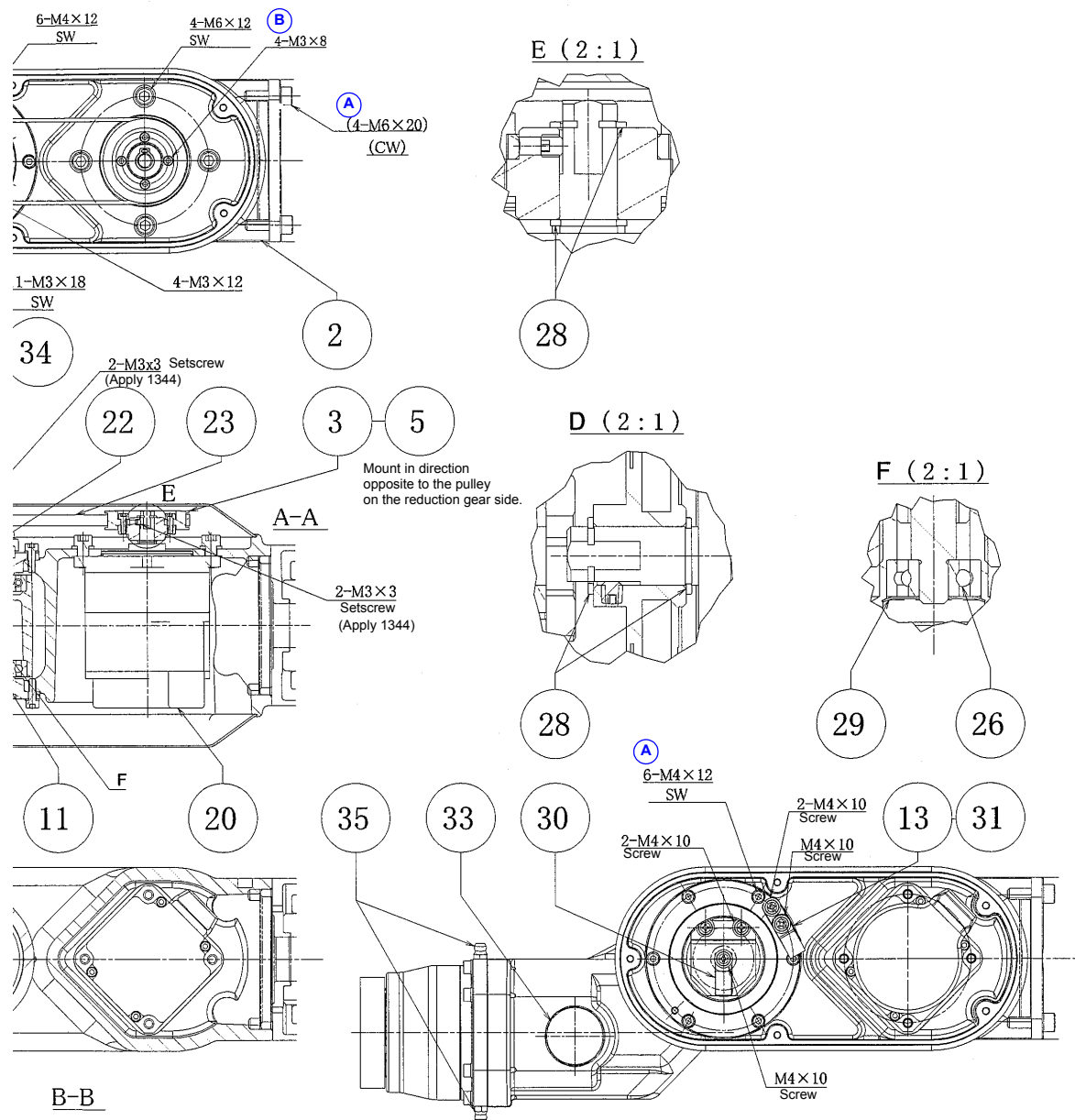

Note

- (1) It is used for UL spec. of YA-1Q series.
- (2) It is used for CE spec. of YA-1Q series.
- (3) It is used for standard spec. of YA-1Q series.
- (4) It is used for short arm spec. of YA-1Q series.

10. 6 BW/TW-axis parts list

No.	Part name	Part number	Q'ty	Note	Class
1	TW body	ADA11091	1		D
2	BW body	ADA11092	1		D
3	Pully H	ADW41060	2		B
4	Pully shaft H	ADS41052	1		D
5	Pully shaft M	ADS41069	1		D
6	HDC housing	ADH32019	1		D
7	BWHDC cover	AGK31029	1		D
8	BWHDC shaft	ADS41054	1		D
9	Key	XPA3F3F8	2		B
10	Bearing fix	ADH32020	1		D
11	TW harness holder	AFM40279	1		D
12	BW cover	ADK32021	2		D
13	Cable spacer	AGA41053	1		D
14	Collar	AMK40057	1		D
15	TW Output flange	ADH40024	1		D
16	TW shaft	ADS30024	1		D
17	B housing TW	ADH30047	1		D
18	TW motor plate	AFP32022	1		D
19	Servo motor	TS4602N8030	1	TW Previous type: TS4602N8023(*)	C
20	Servo motor	TS4606N8323	1	BW	C
21	Harmonic	SG1450QR61T	1	TW	C
22	Harmonic	SG1780QR61B	1	BW	C
23	Timing belt	060S3M339	1		A
24	Bearing	6811LULP03	2		B
25	Bearing	6800ZZ	1		B
26	Bearing	624ZZ	1		B
27	Bearing	6907LUC2LP03	2		B
28	Snap ring	STW8	4		A
29	C-shape snap ring	CRTW14	1		A
30	Nylon clamp	KCA64	1		A
31	Nylon clamp	NK6N	1		A
32	Shim ring	PS45×55×0.2	1		A
33	Hole plug	CP30HP13	2		D
34	U nut	FU00SS	1		A
35	Grease nipple	WA675	2		D
36	Hex. socket head bolt	BOTANBTM3×16	1		D

<Class>

A: Consumable parts, rather short replacement cycle.

B: Assemblies and parts of high frequency in motion.

C: Important electric parts.

D: Parts rather long replacement cycle.

(*) For products manufactured before November, 2007.